

SPECIAL PURPOSE MICROPHONES



AT854R MULTI-CHANNEL CONDENSER BOUNDARY MICROPHONE

Description

The AT854R is a multi-channel boundary microphone with four cardioid condenser elements mounted in a single housing. It is ideal for high-quality sound reinforcement and a variety of video and audio conferencing applications, especially when used with an Audio-Technica automatic SmartMixer®. Its low-profile design makes the AT854R suitable for use in applications where minimum visibility is required.

The four channels of the AT854R, mounted in quadrants, are separate and independent. They can be powered and used individually or in any combination. This permits system integrators to use their own proprietary DSP algorithms for microphone control when incorporating the AT854R into an existing system.

Positioning a properly designed boundary microphone centrally on a large, flat, unobstructed surface yields several distinct advantages. Directionality of the individual elements is increased by 3 dB, promoting enhanced gain before feedback and further suppression of ambient noise. Sensitivity is increased for improved signal-to-noise ratio. Phase distortion due to reflected sound energy from the boundary itself is eliminated.

The AT854R requires 9-52V DC phantom power for each operating channel. A 30' (9.1 m) cable with a miniature multi-contact metal-body plug for connecting to the microphone is included. The cable is custom-manufactured with four separate shielded and jacketed pairs inside a rugged overall jacket. Its output end has four XLRM-type connectors for plugging into a mixer, allowing individual control of each channel.

The microphone is enclosed in a rugged case and protected by two layers of perforated steel. The combination of heavy case and rubber non-slip bottom pad minimizes mechanical coupling of surface vibrations to the microphone. The low-profile housing has a low-reflectance black finish.

Installation and Operation

The symmetry and area of the mounting surface directly affect the sensitivity of the boundary microphone at low frequencies. Ideally, the mounting surface should be circular; however, square or rectangular surfaces are most often used. If the mounting surface is rectangular, the smaller dimension tends to determine low-frequency cutoff. The microphone should be centered on the surface and positioned with the microphone elements facing the sound sources. The sound sources should not be below, or higher than 60° above, the plane of the mounting surface.

Channel numbers are as shown on the top of the mic housing. Outputs are low impedance balanced. The balanced signal appears across the MiniCon connector's Pins 2 and 3 for Mic 1, Pins 4 and 5 for Mic 2, Pins 6 and 7 for Mic 3 and Pins 8 and 9 for Mic 4. The ground (shield) connection for all microphones is Pin 1. Output is phased so that positive acoustic pressure produces positive voltage at the even-numbered pins, which correspond to Pin 2 of each XLR connector of the supplied cable. A table on the back of this sheet summarizes cable connections.

While a modern condenser microphone is not unduly sensitive to the environment, temperature extremes can be harmful. Exposure to high temperatures can result in gradual and permanent reduction of the output level. Avoid leaving the microphone in the open sun or in areas where temperatures exceed 110° F (43° C) for long periods of time. Extremely high humidity should also be avoided.

Architects and Engineers Specifications

The microphone shall be a four-channel fixed-charge condenser with cardioid polar patterns designed for use in surface-mount boundary and conferencing applications. The frequency response shall be 70 Hz to 16,000 Hz. The microphone shall operate from an external 9V to 52V DC phantom power source. Nominal open-circuit output voltage shall be 14.1 mV at 1 kHz, 1 Pascal. Output shall be low impedance balanced (100 ohms).

A 30' (9.1 m) cable with a miniature multi-contact plug at one end and four XLRM-type connectors at the other shall be supplied for connection between the microphone and electronics inputs. The microphone shall have a maximum width of 5.91" (150.0 mm), and a height of 1.09" (27.6 mm). Weight shall be 16.4 oz (465 grams). The microphone shall be housed in a die-cast case with a two-layer perforated steel grille. Finish shall be low-reflectance black.

The Audio-Technica AT854R is specified.

Frequency Response - Each Channel

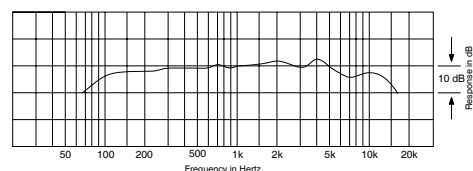

LEGEND ——— 12° or more on axis

AT854R

Polar Pattern - Each Channel

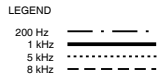
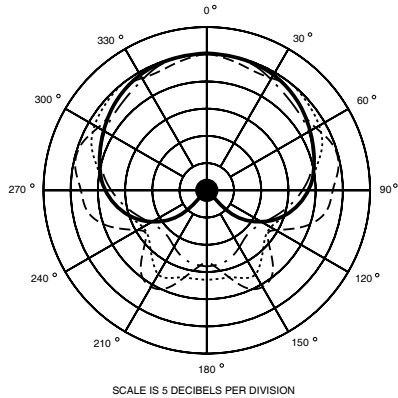

Dimensions

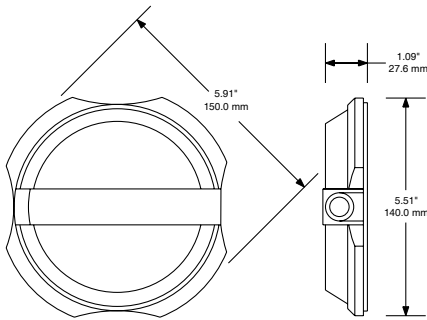

Summary of Cable Connections

Wire Color	MiniCon Pin No.	XLRM - Pin
Shields	All to 1	All XLRMs - Pin 1
Black	2	XLRM 1 - Pin 2
White	3	XLRM 1 - Pin 3
Blue	4	XLRM 2 - Pin 2
Red	5	XLRM 2 - Pin 3
Green	6	XLRM 3 - Pin 2
Gray	7	XLRM 3 - Pin 3
Brown	8	XLRM 4 - Pin 2
Yellow	9	XLRM 4 - Pin 3

AT854R SPECIFICATIONS†

ELEMENT	Fixed-charge back plate permanently polarized condenser
POLAR PATTERN (EACH CHANNEL)	Half-cardioid (cardioid in hemisphere above mounting surface)
FREQUENCY RESPONSE	70-16,000 Hz
OPEN CIRCUIT SENSITIVITY	-37 dB (14.1 mV) re 1V at 1 Pa*
IMPEDANCE	100 ohms
MAXIMUM INPUT SOUND LEVEL	134 dB SPL, 1 kHz at 1% T.H.D.
SIGNAL-TO-NOISE RATIO†	65 dB, 1 kHz at 1 Pa*
DYNAMIC RANGE (TYPICAL)	105 dB, 1 kHz at Max SPL
PHANTOM POWER REQUIREMENTS	9-52V DC, 2 mA typical (each channel)
WEIGHT	16.4 oz (465 grams)
DIMENSIONS	5.91" (150.0 mm) maximum diameter, 1.09" (27.6 mm) high
OUTPUT CONNECTOR	Neutrik MiniCon (9 pins used)
CABLE	30' (9.1 m) long, 0.28" (7.0 mm) diameter shielded cable with a miniature multi-contact plug at microphone end and four independent XLRM-type output connectors

† In the interest of standards development, ATUS offers full details on its test methods to other industry professionals on request.

* 1 Pascal = 10 dynes/cm² = 10 microbars = 94 dB SPL

† Typical, A-weighted, using Audio Precision System One.

Optional Accessories:

- CP8201 line matching transformer (Lo-Z to 50,000 ohms).
- AT8202 adjustable in-line attenuator for use with balanced Lo-Z microphones.
- AT8314 2-conductor, shielded, vinyl-jacketed, broadcast-type cable with XLR-type connector at microphone end, XLRM-type connector at equipment end. Available in 10', 20', 25', 30', 50' & 100' lengths.
- CP8506 four-channel 48V phantom power supply (AC powered).

INFORMATION & IMAGE MANAGEMENT SYSTEMS, S.A.

Valencia, 279, 7ª planta
08009 Barcelona (España)
<http://www.ims.es>

IMS Tel. (34) 93 272 33 00
Fax (34) 93 487 39 00
e-mail: info@ims.es